

## Appendix C

# Proposed Bay Trail At-Grade Crossings and Undercrossings

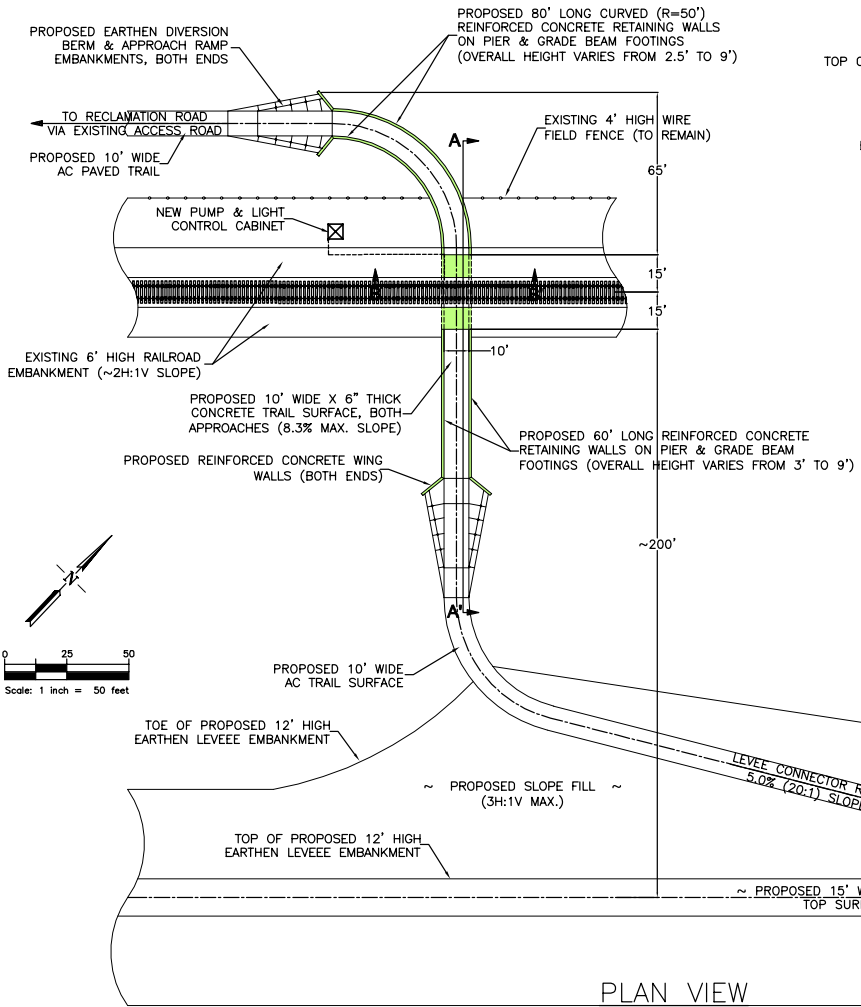



PLAN VIEW  
CONCEPTUAL RAILROAD UNDERCROSSING  
AND LEVEE CONNECTOR  
(SCALE 1"=50')

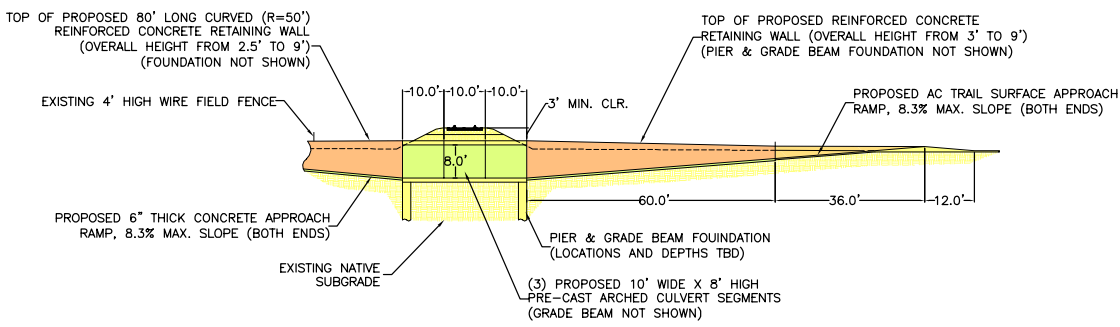

SECTION A-A'  
(HOR. & VERT. SCALE 1"=30')

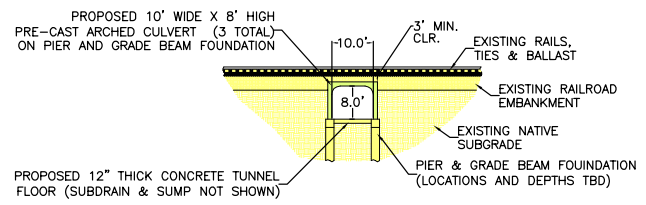
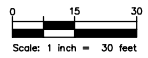

SECTION B-B'  
(HOR. & VERT. SCALE 1"=30')

- NOTES**
- 1) SURFACE DRAIN AND SUBDRAIN SYSTEM DETAILS NOT SHOWN.
  - 2) FOUNDATION DETAILS NOT SHOWN, DESIGN TBD.
  - 3) CONCEPT ASSUMES EXISTING RAILROAD BED TO SUPPORTED AND NEAR CROSSING INSTALLED WITH MINIMAL TRAFFIC DISRUPTION.

SEARS POINT BAY TRAIL  
FEASIBILITY STUDY



DESIGN	
DRAWN	JCM
CHECKED	
APPRD	JHP
DATE	09/24/07
PROJECT NUMBER	

**QUESTA**  
ENGINEERING CORP.

Civil  
Environmental  
& Water Resources

(510) 236-6114  
FAX (510) 236-2423  
questa@questac.com

P.O. Box 70356 1220 Brickyard Cove Road Point Richmond, CA 94807

RAILROAD  
UNDERCROSSING

SHEET

7



PLAN VIEW  
EXISTING HIGHWAY 37  
UNDERCROSSING  
(SCALE 1"=40')

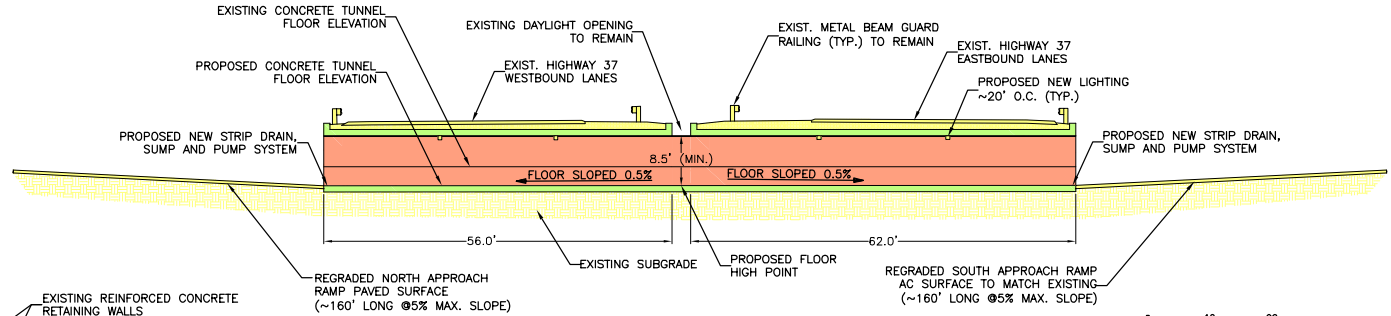
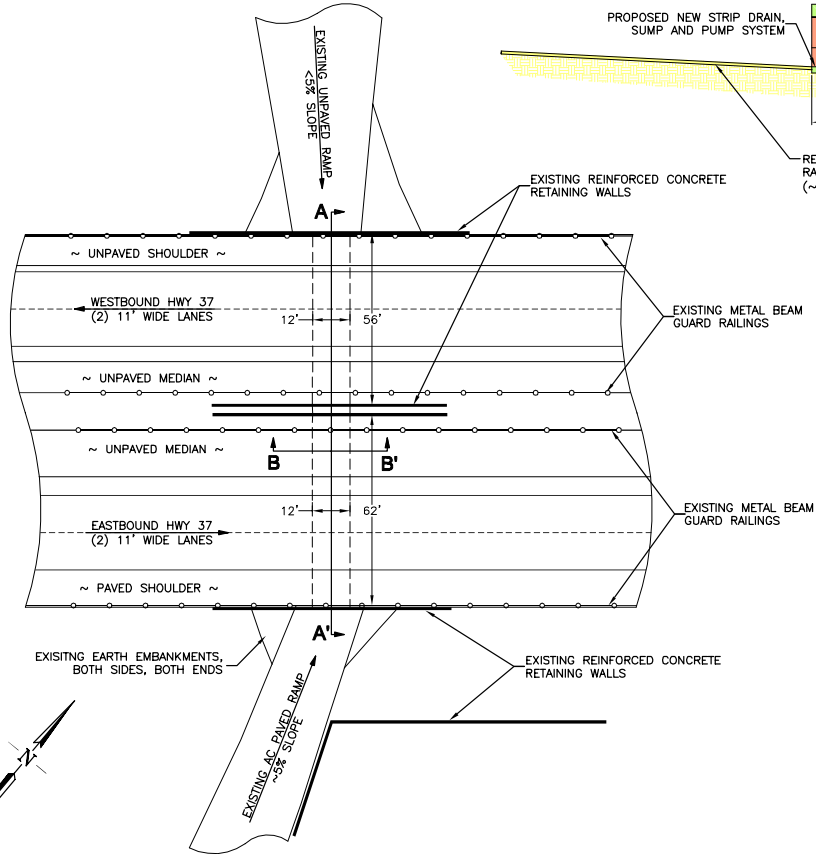

PROPOSED SECTION A-A'  
(HOR. & VERT. SCALE 1"=20')

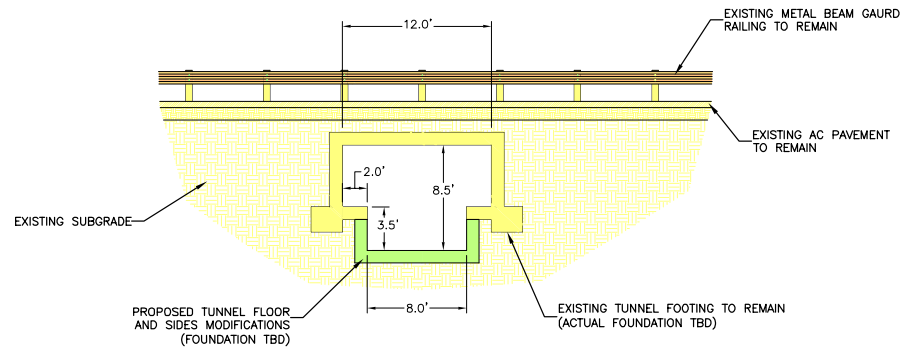
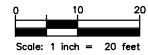

PROPOSED SECTION B-B'  
(HOR. & VERT. SCALE 1"=10')

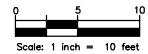

- NOTES
- 1) FEATURES AND DIMENSIONS SHOWN ARE APPROXIMATE.
  - 2) SURFACE DRAIN AND SUBDRAIN SYSTEM DETAILS NOT SHOWN.
  - 3) FOUNDATION MODIFICATIONS NOT SHOWN, DESIGN TBD.
  - 4) CONCEPT ASSUMES EXISTING TUNNEL FLOOR TO BE SAWCUT AND NEW FLOOR EXCAVATED AND CAST IN PLACE WITHOUT DISRUPTING TRAFFIC FLOW.

SEARS POINT BAY TRAIL  
FEASIBILITY STUDY



DESIGN  
DRAWN JCM  
CHECKED  
APPRD JHP  
DATE 09/24/07  
PROJECT NUMBER



HIGHWAY  
UNDERCROSSING

SHEET

8



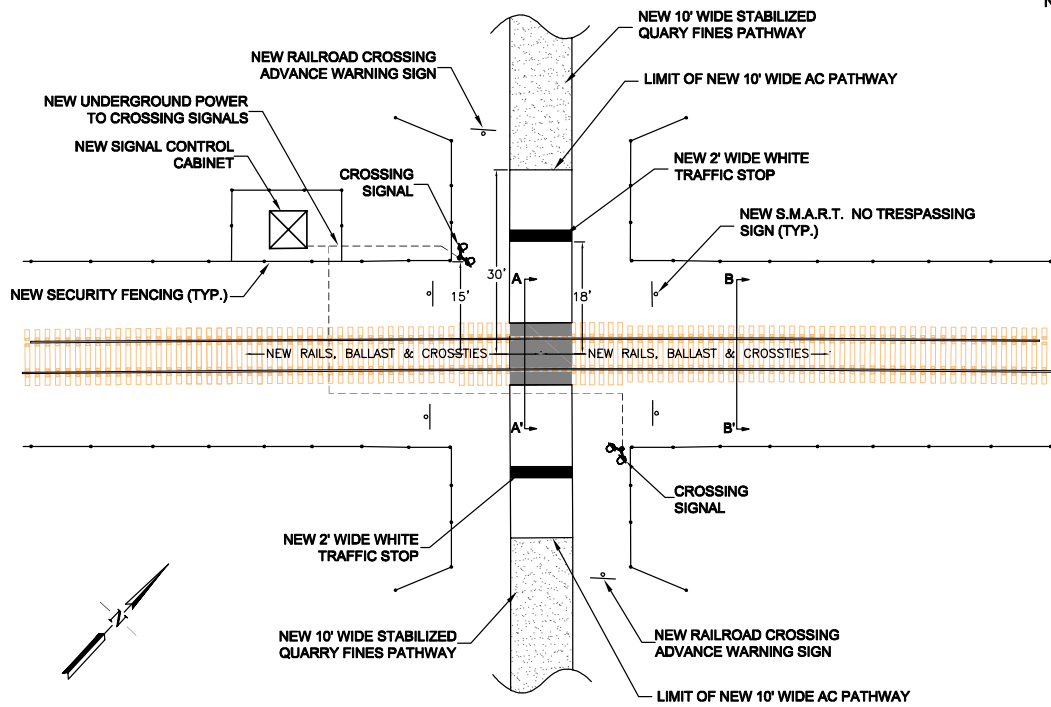

TRAIL PLAN VIEW AT RAILROAD CROSSING  
(SCALE 1" = 20')

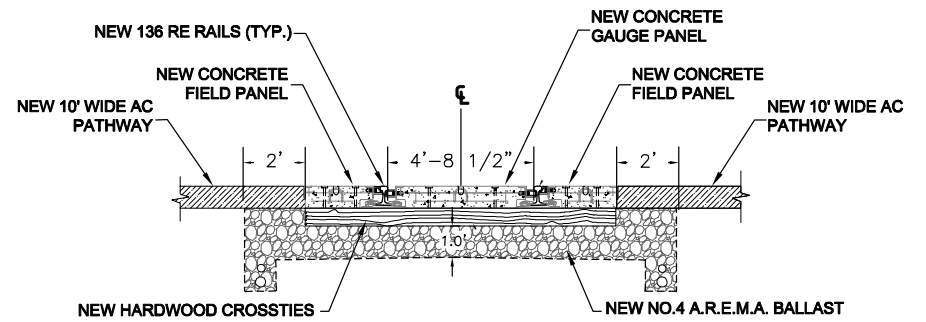

SECTION A-A' NEW TRAIL CROSSING  
(SCALE 1" = 8')

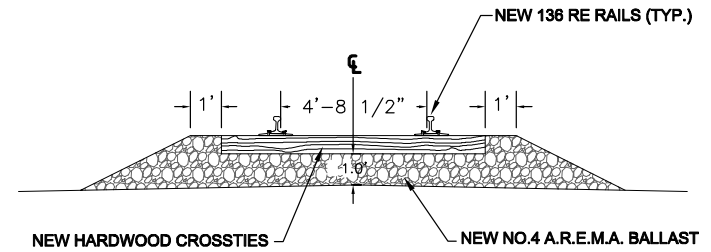

SECTION B-B' NEW OPEN TRACK  
(SCALE 1" = 8')

SEARS POINT BAY TRAIL  
FEASIBILITY STUDY



DESIGN  
DRAWN JCM  
CHECKED  
APPRD JHP  
DATE 09/24/07  
PROJECT NUMBER

**QUESTA**  
ENGINEERING CORP.  
Civil  
Environmental  
& Water Resources  
(510) 236-6114  
FAX (510) 236-2423  
questa@questac.com  
P.O. Box 70356 1220 Brickyard Cove Road Point Richmond, CA 94807

AT GRADE  
RAILROAD CROSSING

SHEET

9

